

Haiwell PLC User Manual

Programmable Logic Controller

H/N series PLC MPU user manual



Contents

1. Product Model List & Dimensions.....	3
2. Indicator Description.....	3
3. Power Supply Specification.....	4
4. Environmental specifications for Product.....	4
5. Digital Input (DI) Specification.....	4
6. Digital Output (DO) Specification.....	4
7. Digital Input/Output (DI/DO) Wiring.....	5
8. MPU Terminal Wiring Diagram.....	5
9. Mounting and installation.....	6
10. Programming Cable Wiring.....	6
11. Address Setting.....	6
12. Power Supply Wiring.....	6

1. Product Model List & Dimensions

Ethernet Model	24VDC	Ethernet Model	220VAC	Model	24VDC	Model	220VAC	Dimension
H16S0R-e	0.56A	H16S2R-e	10.2W	H16S0R	0.53A	H16S2R	9.6W	93×95×82mm
H16S0T/P-e	0.58A	H16S2T/P-e	10.9W	H16S0T/P	0.55A	H16S2T/P	10.3W	
N16S0T/P-e	0.58A	N16S2T/P-e	10.7W	N16S0T/P	0.55A	N16S2T/P	10.1W	
H24S0R-e	0.6A	H24S2R-e	11.3W	H24S0R	0.57A	H24S2R	10.7W	
H24S0T/P-e	0.62A	H24S2T/P-e	11.7W	H24S0T/P	0.59A	H24S2T/P	11.1W	
N24S0T/P-e	0.62A	N24S2T/P-e	12.3W	N24S0T/P	0.58A	N24S2T/P	11.7W	
H32S0R-e	0.64A	H32S2R-e	13.1W	H32S0R	0.61A	H32S2R	12.5W	131×95×82mm
H32S0T/P-e	0.66A	H32S2T/P-e	12.7W	H32S0T/P	0.63A	H32S2T/P	12.1W	
H40S0R-e	0.68A	H40S2R-e	13.3W	H40S0R	0.65A	H40S2R	12.7W	
H40S0T/P-e	0.7A	H40S2T/P-e	14.7W	H40S0T/P	0.67A	H40S2T/P	14.1W	
N40S0T/P-e	0.71A	N40S2T/P-e	14.9W	N40S0T/P	0.68A	N40S2T/P	14.3W	
H60S0R-e	0.78A	H60S2R-e	17.1W	H60S0R	0.75A	H60S2R	16.5W	
H60S0T/P-e	0.8A	H60S2T/P-e	17.8W	H60S0T/P	0.77A	H60S2T/P	17.2W	
N60S0T/P-e	0.81A	N60S2T/P-e	17.9W	N60S0T/P	0.78A	N60S2T/P	17.3W	

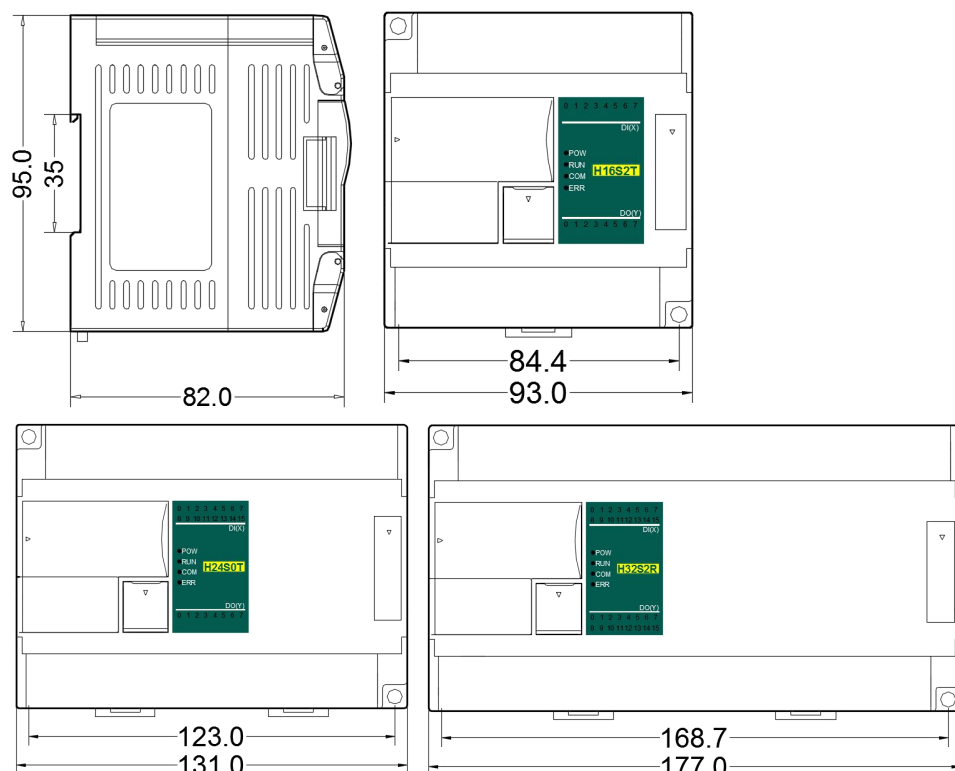

2. Indicator Description

- ① PWR: Power indicator,green. Continuous ON - Power good; OFF - Power error.
- ② RUN: Running indicator,green. Continuous ON - PLC is in running state; OFF - PLC was shutdown.
- ③ COM: Communication indicator,green. Flickering - PLC is in communicating state, the flicker frequency indicates the speed of the communication; OFF - No communication.
- ④ ERR: Erroe indicator .double (red. yellow), as follows

Consult manage	Signify information type	ERR the state of the indicator
Normal	Without error	Not light
Normal,just prompt take attention to the locked data	PLC have the component which locked	Yellow flicker:On 0.2 seconds and Off 0.8 seconds
Modificate the PLC hardward configure	Problem in the soft seting ,permit user keep on operate the user program	Yellow flicker:On 0.2 seconds and Off 0.8 seconds
Check module parallel bus (check the RTC battery; check extension module power supply)	Communication abnormal between modul,auto dislodge the abnormal module,permit user keep on operate the user program	Yellow flicker:On 0.8 seconds and Off 0.2 seconds
Upgrade the fireware or modify the user program	Fireware abnormal or user program abnormal,can not operate the user program	Red slowly flicker:indicator light 0.5s not light 0.5s
Maintain	Hardware error,user program con not running	yellow constant light

3. Power Supply Specification

Item	AC Power Supply	DC Power Supply
Power Supply Voltage	100~240VAC	DC24V -15%~+20%
Power Supply Frequency	50~60Hz	—
Power Consumption	25VA MAX	—
Instantaneous Surge	20A 1.5ms MAX @220VAC	20A 1.5ms MAX @24VDC
Power Loss Time	20ms or less @220VAC	10ms or less
Fuse	2A, 250VAC	2A, 250VAC
5V Output Voltage (for CPU)	5V, -2%~+2%, 1.2A MAX	5V, -2%~+2%, 1.2A MAX
24V Output Voltage (for output and extension)	24V, -15%~+15%, 500mA MAX	24V, -15%~+15%, 500mA MAX
24V Output Voltage (for input and peripheral)	24V, -15%~+15%, 300mA MAX	Use external 24VDC power supply
Insulation Type	Transformer isolation or optoelectronic isolation ,1500VAC/1 minute	No Electrical isolation
Power Protection	DC24V output over current	DC input power polarity reverse, over voltage

4. Environmental specifications for Product

Item	Environment Specification
Temperature/Humidity	Operating temperature:0~+55℃ Storage temperature:-25~+70℃ Humidity: 5~95%RH, No condensation
Vibration Resistance	10~57 HZ, amplitude=0.075mm, 57HZ~150HZ acceleration=1G, 10 times each for X-axis, Y-axis and Z-axis
Impact Resistance	15G, duration=11ms, 6 times each for X-axis, Y-axis and Z-axis
Interference Immunity	AC EFT:±2500V Surge:±2500V DC EFT:±2500V Surge:±1000V
Over Voltage Resistance	1500VAC/1min between AC terminal and PE terminal, 500VAC/1min between DC terminal and PE terminal
Insulation Impedance	≥5MΩbetween AC terminal and all input/output points to PE terminal @500VDC
Ground	The third kind of grounding(Connecting to the ground of high voltage system is prohibited)
Operating environment	Avoid dust, moisture, corrosion, electric shock and external shocks

5. Digital Input (DI) Specification

Item	Digital Input (DI)
Input Signal	No voltage contact or NPN/PNP
Action driving	ON>3.5mA OFF<1.5mA
Input Impedance	Input Impedance≈4.3KΩ
Maximum Input Current	10mA
Reaction Time	6.4ms DEFAULT, can be configured to 0.8~51.2ms
Insulation Type	Optoelectronic isolation for each channel
Input Indication	LED's lighting indicates ON, no light indicates OFF
Power supply	MPU internal power supply:DC power supply (SINK or SOURCE) 5.3mA@24VDC

6. Digital Output (DO) Specification

Item	Output point type : Relay - R	NPN or PNP transistor output T/P
Maximum load	Resistive Load	2A/1 point, 8A/4 points COM
	Inductive Load	50VA
	Lamp load	100W
Minimum Load	10mA	2mA
Voltage Specification	Below 250VAC, 30VDC	30VDC
Drive Capability	Maximum contact capacity: 5A/250VAC	1A MAX, 10 seconds
Reaction Time	Off→On 10ms, On→off 5ms	Off→On 10μs, On→Off 120μs
Insulation Type	Mechanical isolation	Optoelectronic isolation for each channel
Output Indication	LED's lighting indicates ON, no light indicates OFF	
Power Supply	MPU internal 24VDC power supply	

7. Digital Input/Output (DI/DO) Wiring

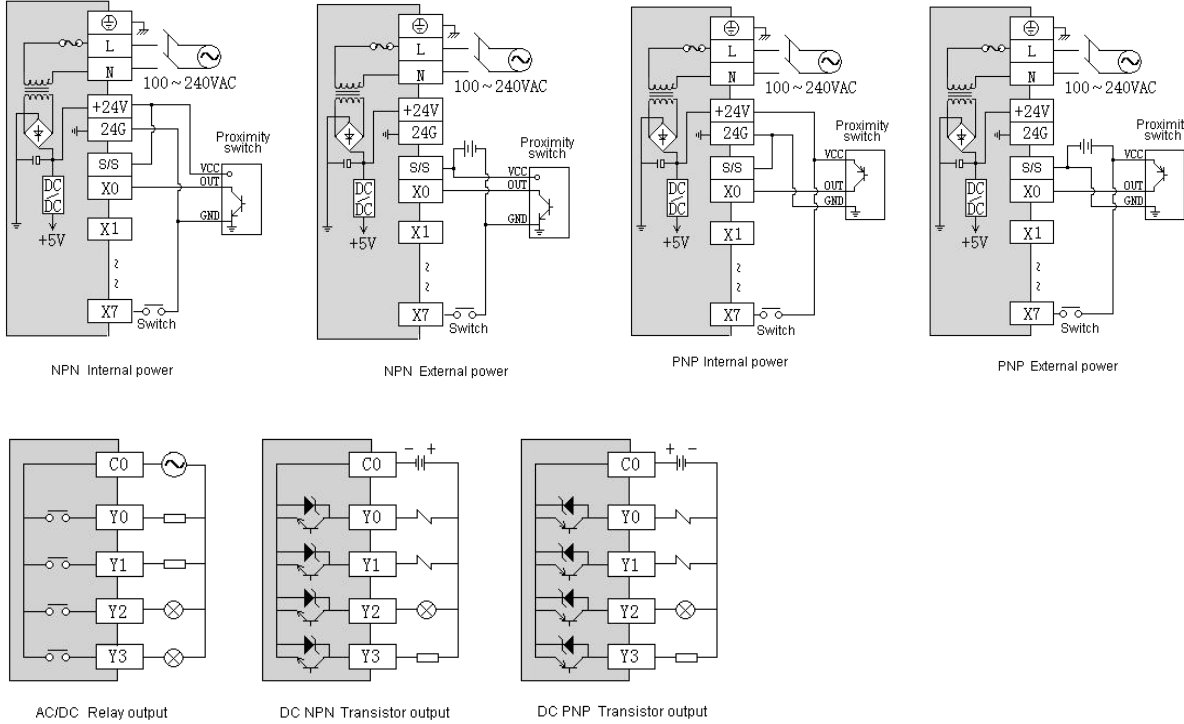

8. MPU Terminal Wiring Diagram

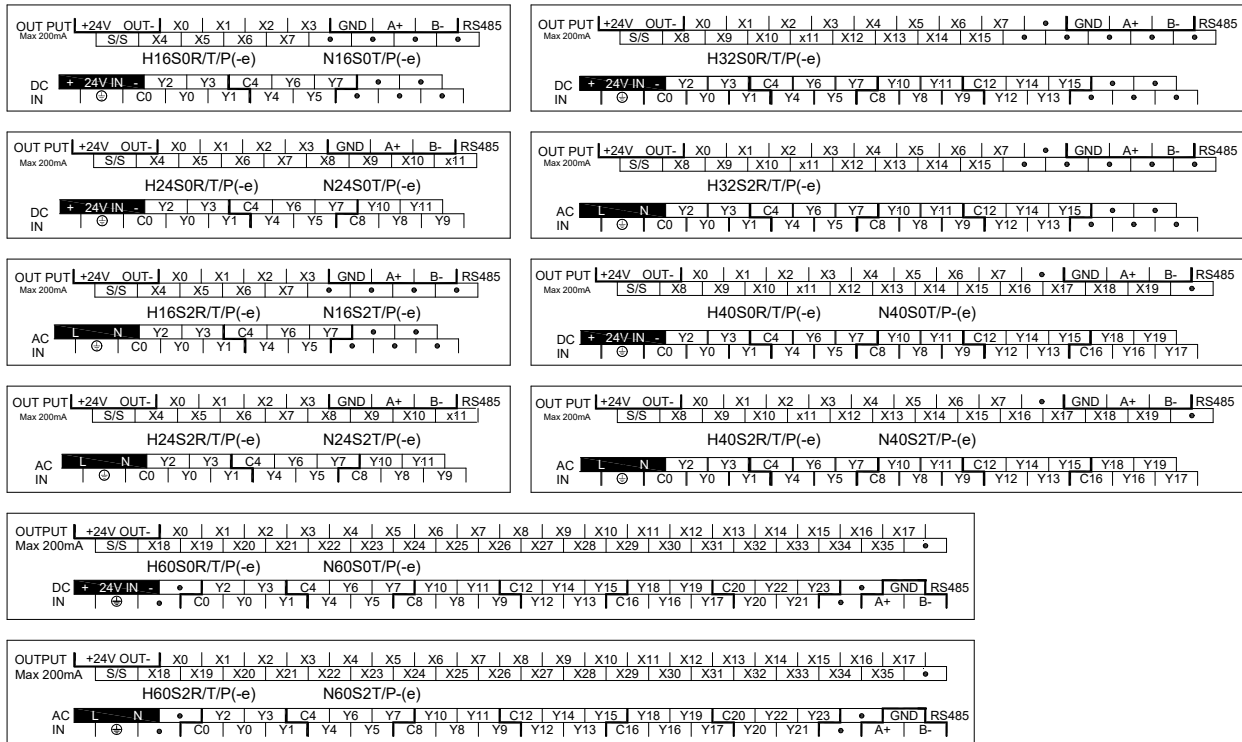

9. Mounting and installation

The PLC should be secured to an enclosed cabinet while mounting. For heat dissipation, make sure to provide a minimum clearance of 50mm between the unit and all sides of the cabinet. (See the figure.)

Rail Mounting: Use standard 35 mm rail.

Screw Mounting: Each MPU or extension module has two positioning screw holes, the diameter of the hole is 4.5mm. Please refer to the dimension figure for the location of the positioning holes and their spacing.

To avoid over temperature and for a better heat dissipation, do not mount PLC to a position near to the bottom/top of the cabinet. Do not mount PLC in vertical direction.

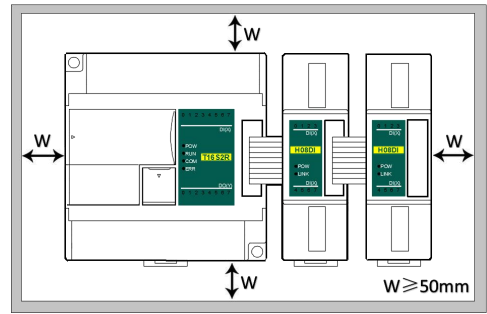

Extension Module Wiring: Connections between extension modules and connections between module and MPU are achieved through bus. An extension cable will be configured to every extension module, for the connection between two different modules.

Connection methods: turn the right side of extended interface (the last MPU or extension module) over, plug the extension cable in the extended interface, then press down the cover of the extended interface to reset the interface, the extended interface at the right side of the module will be reserved for extension of the next module. Connect all extension modules in turn in the same way.

10. Programming Cable Wiring

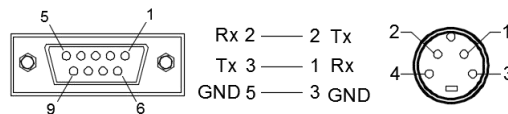

Computer side (RS-232) DB9 female

PLC side (COM1) 4 core S terminal male

11. Address Setting

Haiwell PLC with Ethernet port, the default IP address is : 192.168.1.111, subnet mask: 255.255.255.0, gateway: 192.168.1.1. Hardware DIP dial switch address range: 1-15, the default address is 1. If you need to set a bigger address range, you can set on the software after connection with PLC, it can be set on the PLC parameter option in the software menu by checking on the "soft address" with the range of 1-254(the soft address is prior to the hardware dial address).

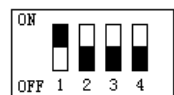

12. Power Supply Wiring

There are two kinds of power supplies for PLC: AC input and DC input. Please pay particular attention to the following notes:

- AC input voltage is 100~240VAC 50/60Hz unless otherwise stated. Connecting any one of the AC input wires to the terminal-L and terminal-N on the MPU will be OK, but for safety's sake, please connect the two wires (Live Wire & Neutral Wire) of AC input to terminal-L and terminal-N respectively.
- ⚠ Any AC110V or AC220V connected to the +24V terminal or input points will permanently damage the PLC.
- Please use wires of 2.5mm or above for the grounding of the MPU.